

Pump Pompa	Pressure Pressione		Volume Portata				RPM giri/min		Power Potenza			
			l/min		GPM				HP		kW	
	bar	PSI	50 Hz	60 Hz	50 Hz	60 Hz	50 Hz	60 Hz	50 Hz	60 Hz	50 Hz	60 Hz
XXT4215HTI	150	2175	42,6	51,1	11,3	13,6	1450	1740	16,4	19,7	12,1	14,5
XXT5515HTI	150	2175	55,1	66,1	14,6	17,5	1450	1740	21,5	26,0	15,9	19,1
XXT7012HTI	120	1740	70,0	84,0	18,5	22,2	1450	1740	21,7	26,0	16,0	19,2

Dimensioni d'ingombro

Overall dimensions

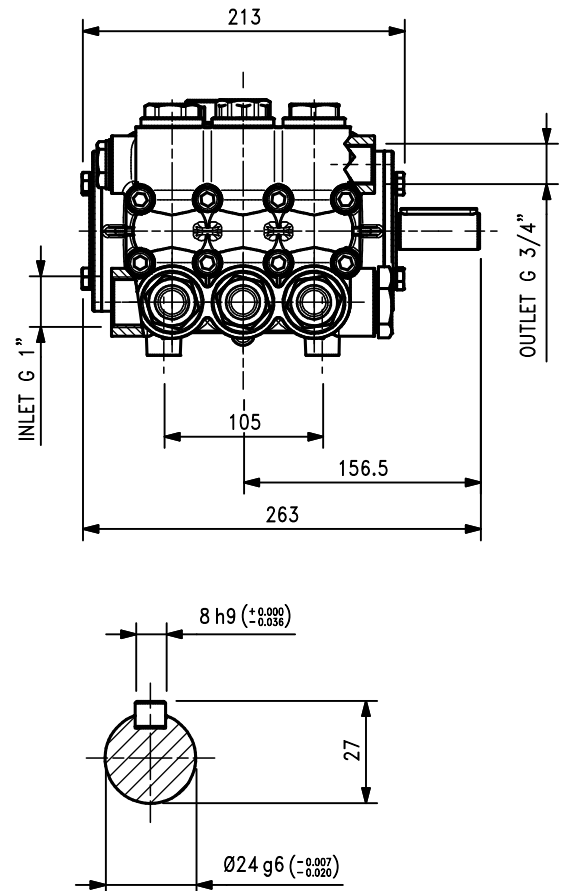

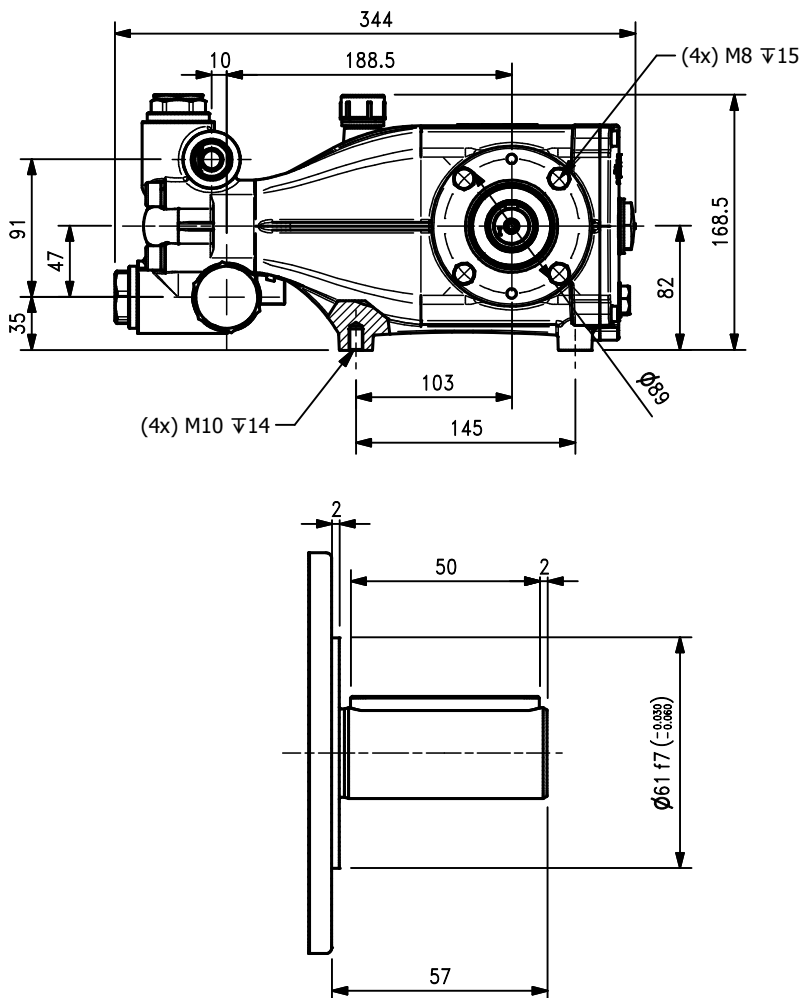
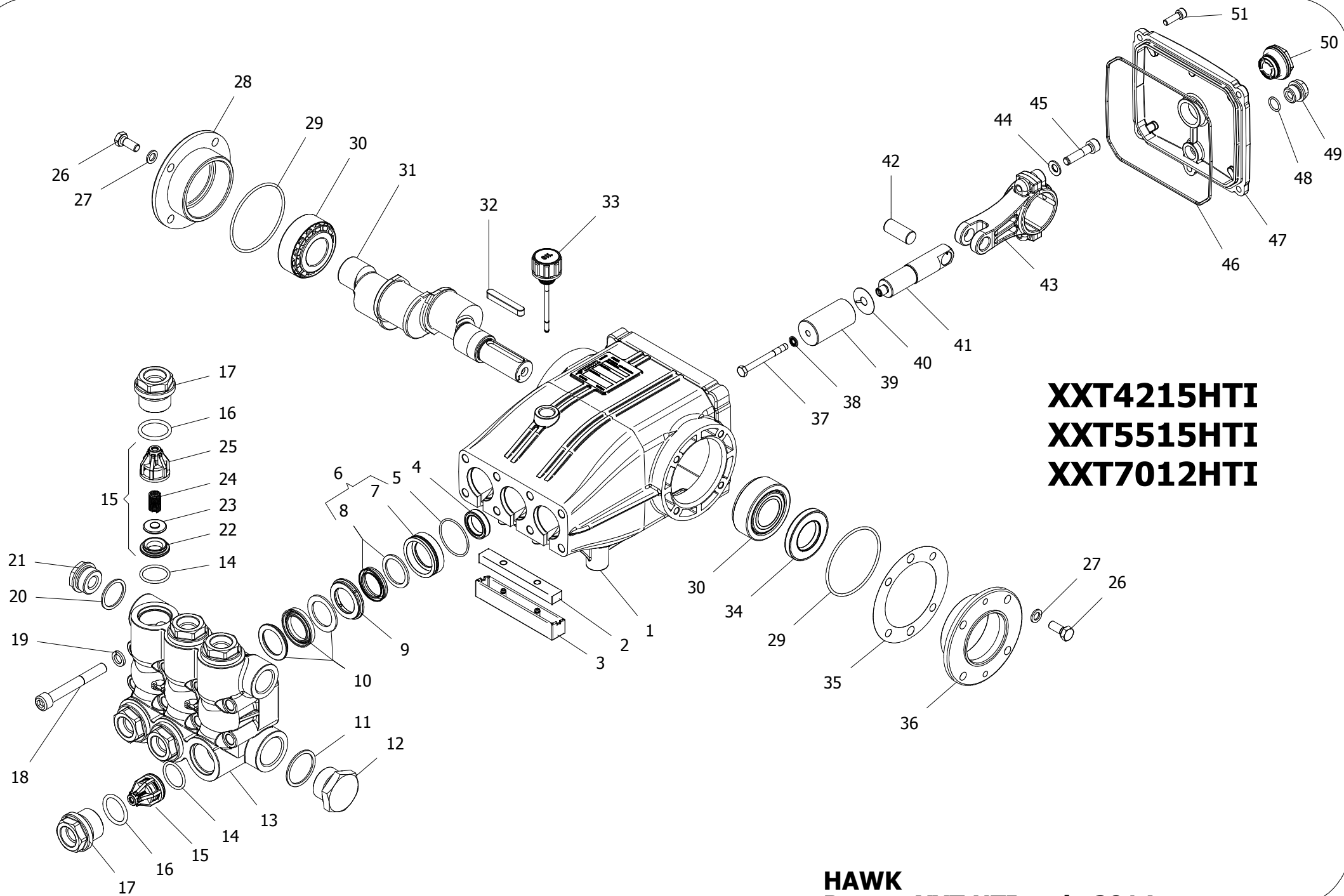

XXT4215HTI
XXT5515HTI
XXT7012HTI

HAWK
Pompe XXT HTI serie 2014
XXT HTI pumps 2014 series

rev. 5.0

Posizioni	Part Number & Description	Codice e Descrizione	Q.tà Pompa	XXT7012HTI	XXT5515HTI	XXT4215HTI
3x (5- 6- 10)	2602.33 Plunger Seals 22	2602.33 Guarnizioni pistone Ø22	1			◆
	2602.36 Plunger Seals 25	2602.36 Guarnizioni pistone Ø25	1		◆	
	2601.51 Plunger Seals 28	2601.51 Guarnizioni pistone Ø28	1	◆		
5- 6- 9- 10	2602.34 Complete seal Packing 22 mm	2602.34 Pacco completo Guarnizioni pistone Ø22	3			◆
	2602.37 Complete seal Packing 25 mm	2602.37 Pacco completo Guarnizioni pistone Ø25	3		◆	
	2602.39 Complete seal Packing 28 mm	2602.39 Pacco completo Guarnizioni pistone Ø28	3	◆		
37- 38- 39- 40	2601.29 Plunger 22	2601.29 Pistone Ø22	3			◆
	2601.17 Plunger 25	2601.17 Pistone Ø25	3		◆	
	2601.18 Plunger 28	2601.18 Pistone Ø28	3	◆		
14- 15- 16	2601.44 Complete Valve	2601.44 Valvola completa	6	◆	◆	◆
3x (4)	2600.03 Plunger oil Seal	2600.03 Anelli tenuta olio Asta	1	◆	◆	◆
5- 6- 9- 10- 11 12- 13- 14- 15 16- 17- 20- 21	2602.40 Complete Manifold 22	2602.40 Testata Completa Ø22	1			◆
	2602.41 Complete Manifold 25	2602.41 Testata Completa Ø25	1		◆	
	2602.42 Complete Manifold 28	2602.42 Testata Completa Ø28	1	◆		
41- 42- 43- 44 45	3100.43 Connectin Rod Plunger Rod Assy	3100.43 Premontato asta-biella	3	◆	◆	◆

Pos.	Codice		Descrizione	Q.tà/Po mpa	XXT7012HTI	XXT5515HTI	XXT4215HTI
1	0202.97	Crankcase	Carter	1			
2	1511.00	Polyester Fiber Sponge	Spugna poliestere	1			
3	1702.00	Drainage Tank	Vaschetta	1	◆	◆	◆
*4	0001.01	Plunger oil seal	Anello radiale	3			
*5	0601.08	"O" Ring Ø1.78x37.82	"O" Ring Ø1.78x37.82	3			
*6	3604.84	Low pressure seal assembly Ø22	Premontato tenute bassa pressione Ø22	3			◆
	3604.85	Low pressure seal assembly Ø25	Premontato tenute bassa pressione Ø25	3		◆	
	3604.86	Low pressure seal assembly Ø28	Premontato tenute bassa pressione Ø28	3	◆		
*7	1201.69	Pressure ring 22 mm	Pressore Ø22	3			◆
	1201.70	Pressure ring 25 mm	Pressore Ø25	3		◆	
	1201.65	Pressure ring 28 mm	Pressore Ø28	3	◆		
*8	0002.80	"U" seal, dia.22 mm	Anello tenuta "U" Ø22	3			◆
	0002.82	"U" seal, dia.25 mm	Anello tenuta "U" Ø25	3		◆	
	0002.84	"U" seal, dia.28 mm	Anello tenuta "U" Ø28	3	◆		
*9	0300.89	Intermed. ring 22mm	Diffusore interm. Ø22	3			◆
	0300.90	Intermed. ring 25mm	Diffusore interm. Ø25	3		◆	
	0300.87	Intermed. ring 28mm	Diffusore interm. Ø28	3	◆		
*10	0002.79	"U" seal, dia.22 mm	Anello tenuta "U" Ø22	3			◆
	0002.81	"U" seal, dia.25 mm	Anello tenuta "U" Ø25	3		◆	
	0002.83	"U" seal, dia.28 mm	Anello tenuta "U" Ø28	3	◆		
*11	0603.12	Copper washer G1"	Guarnizione rame G 1"	1	◆	◆	◆
*12	1601.88	Nickel Plated Brass plug G1"	Tappo G 1" Nichelato	1			
*13	1602.65	Nickel Plated Manifold housing Ø28/Ø25	Testata Nichelata Ø28/Ø25	1	◆	◆	
	1602.66	Nickel Plated Manifold housing Ø22/Ø20	Testata Nichelata Ø22/Ø20	1			◆
*14	0601.66	"O" Ring Ø2,62x25,07	"O" Ring Ø2,62x25,07	6			
*15	3604.77	Valve assembly	Valvola premontata	6			
*16	0601.67	"O" Ring Ø3.53x26.58	"O" Ring Ø3.53x26.58	6			
*17	1601.87	Nickel Plated Valve plug	Tappo valvola nichelato	6			
18	1801.40	Manifold stud bolt	Vite M10x80	8			
19	1403.01	Lock-Washer	Rosetta elastica Ø10,2	8			
*20	0603.11	Copper washer G3/4	Guarnizione rame G3/4	1			
*21	1601.78	Nickel Plated Brass plug G3/4	Tappo G3/4 Nichelato	1			
22	1503.43	Valve seat	Sede valvola	6			
23	1202.13	Valve plate	Piattello valvola	6			
24	0900.39	Valve spring	Molla valvola	6			
25	0604.14	Valve cage	Gabbia valvola	6	◆	◆	◆
26	1802.05	Hexagonal screw	Vite M8x20	8			
27	1400.01	Washer	Rosetta Ø8.5	8			
28	0500.58	Closed bearing housing	Flangia chiusa	1			
29	0601.00	"O" Ring Ø2.62x71.12	"O" Ring Ø2.62x71.12	2			
30	0200.05	Roller bearing	Cuscinetto a rulli	2			
31	0006.47	Crankshaft Ø24	Albero eccentrico Ø24	1			
32	0206.05	Crankshaft key	Chiavetta	1			
33	1600.16	Oil dip stick	Tappo livello olio	1			
34	0001.00	Cranckshaft seal	Anello radiale	1			
35	0301.00	Shim	Distanziale	1			
36	0500.11	Bearing housing	Flangia aperta	1			

XXT HT I 2014

PARTS LIST

LISTA PARTI

Pos.	Codice		Descrizione	Q.tà/Po mpa	XXT7012HTI	XXT5515HTI	XXT4215HTI
*37	1802.23	Plunger bolt	Vite pistone	3	◆	◆	◆
*38	1400.10	Copper spacer	Rosetta rame	3			
*39	1200.34	Plunger 22 mm	Pistone Ø22	3			◆
	1200.33	Plunger 25 mm	Pistone Ø25	3		◆	
	1200.30	Plunger 28 mm	Pistone Ø28	3	◆		
*40	1400.57	Copper spacer	Rosetta rame	3			
*41	0003.33	Plunger rod	Asta pistone	3			
*42	1502.07	Connecting rod pin	Spinotto	3			
*43	0100.10	Connecting rod	Biella completa	3			
*44	1401.03	Spring washer	Rosetta elastica Ø8	6			
*45	1801.01	Connecting rod screw	Vite M8x35	6	◆	◆	◆
46	0601.85	"O" Ring Ø2,62x152,07	"O" Ring Ø2,62x152,07	1			
47	0203.63	Crankcase cover	Coperchio	1			
48	0601.14	"O" Ring Ø1,78x14,00	"O" Ring Ø1,78x14,00	1			
49	1601.17	Brass plug 3/8	Tappo G3/8	1			
50	0700.05	Sight glass, G3/4	Spia livello olio G3/4	1			
51	1801.41	Cover screw	Vite M6x20	5			

Part available in kit only

Particolare disponibile solo in kit

* Part available in kit also

Particolare disponibile anche in kit