

Pump Pompa	Pressure Pressione		Volume Portata				RPM giri/min		Power Potenza			
			l/min		GPM				HP		kW	
	bar	PSI	50 Hz	60 Hz	50 Hz	60 Hz	50 Hz	60 Hz	50 Hz	60 Hz	50 Hz	60 Hz
MXT1015HT	150	2175	100	120	25,9	31,1	1450	1740	37,7	45,2	27,7	33,2
MXT8515HT	150	2175	85	102	22,2	26,6	1450	1740	32,3	38,8	23,8	28,6
MXT7015HT	150	2175	70	84	18,5	22,2	1450	1740	26,9	32,3	19,8	23,8

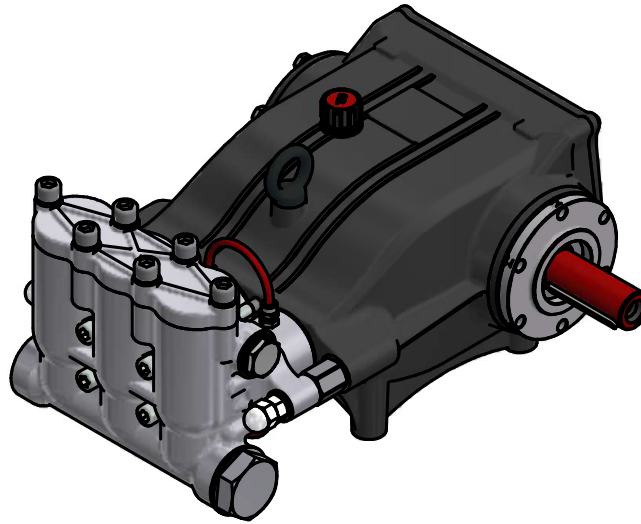

Dimensioni d'ingombro

Overall dimensions

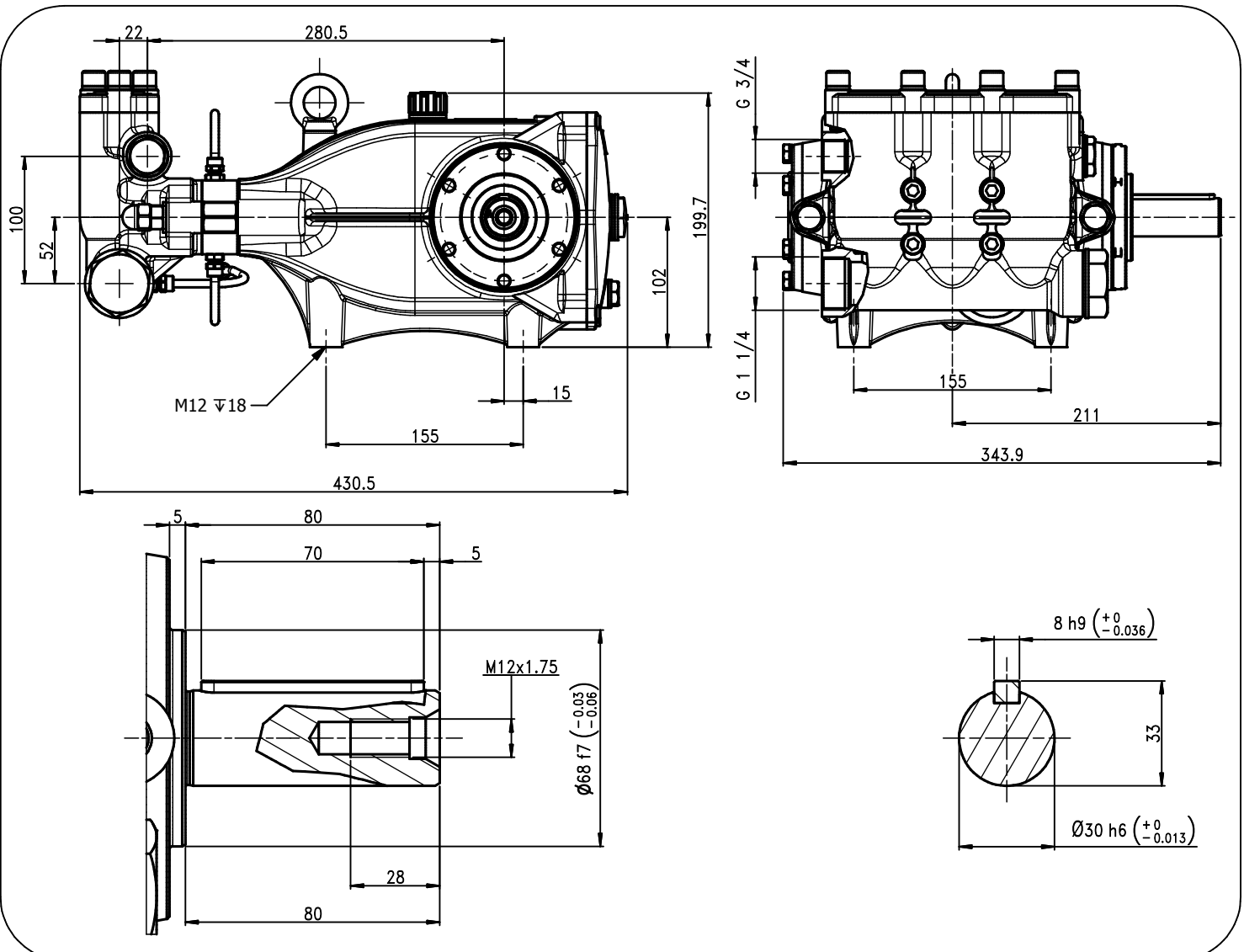

Lubrificazione: Olio SAE 10W-40
 Capacità: 2,3 Litri
 Peso pompa: 28,5 Kg

Rev. 3

Lubrication: SAE 10W-40 Oil
 Capacity: 2,3 Litres
 Weight: 28,5 Kg

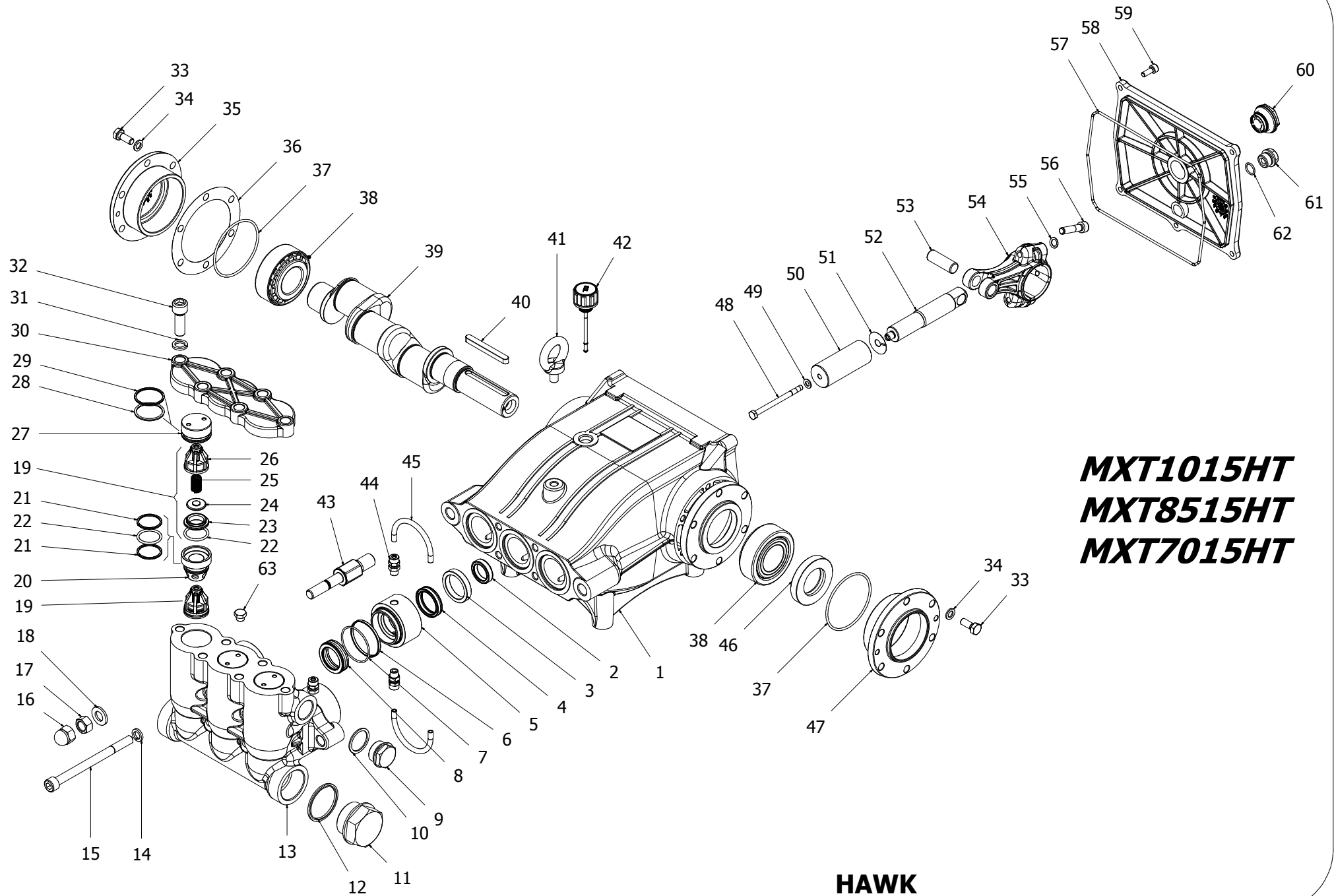

MXT1015HT
MXT8515HT
MXT7015HT

HAWK
serie MXT HT
MXT HT series

MXT HT

SPARE PARTS KIT

KIT RICAMBI

Item Posizioni	Part Number Codice	Description	Descrizione	Q.ty Pump Q.tà Pompa	MXT1015HT	MXT8515HT	MXT7015HT
3-4-6-7-8	2602.88	<i>Plunger seals</i>	Guarnizioni pistone	1	◆	◆	◆
3-4-5-6 7-8	2602.89	<i>Complete seal packing</i>	Pacco completo guarnizioni pistone	3	◆	◆	◆
48-49 50-51	2602.83	<i>Plunger</i>	Pistone	3	◆	◆	◆
2x19 2x21 22-28-29	2602.84	<i>Complete Valve</i>	Valvola completa	3	◆	◆	◆
2	2600.03	<i>Plunger oil seal</i>	Anelli tenuta olio asta	1	◆	◆	◆
3-4-5-6-7 8-9-10-11 12-13-16 17-18-19 20-21-22 23-24-25 26-27-28 29-30-31 32-43-44 45	2602.90	<i>Plunger Manifold</i>	Testata completa	1	◆	◆	◆
52-53-54 55-56	3100.45	<i>Connectin rod-Plunger rod assy</i>	premontato asta-biella	3	◆	◆	◆

MXT HT

PARTS LIST

LISTA PARTI

Item Posizioni	Part Number Codice	Description	Descrizione	Q.ty Pump Q.tà Pompa	MXT1015HT	MXT8515HT	MXT7015HT
1	0202.89	CARTER	CARTER	1			
2*	0001.01	PLUNGER OIL SEAL	ANELLO RADIALE	3			
3*	1201.86	SUPPORT RING	PRESSORE	3			
4*	0002.97	"U" SEAL HT	GUARN. "U" HT	3			
5*	0303.00	INTERMED. RING	DIFFUSORE	3			
6*	0009.58	BACK RING	ANELLO ANTIESTR.	3			
7*	0605.26	O-RING	O-RING	3			
8*	0002.92	"U" SEAL	GUARN. "U"	3			
9*	1601.78	BRASS PLUG G3/4"	TAPPO G3/4	1			
10*	0603.11	COPPER SPACER G3/4"	GUARNIZIONE G3/4"	1			
11*	1601.98	BRASS PLUG G1" 1/4	TAPPO G1" 1/4	1			
12*	1408.14	BONDED SEAL G 1" 1/4 NBR	BONDED SEAL G 1" 1/4 NBR	1			
13*	1602.72	MANIFOLD HOUSING	TESTATA OTTONE	1			
14*	1403.01	SPRING WASHER	ROSETTA ELAST.	4			
15*	1801.52	MANIFOLD HOUSING SCREW	VTCEI M10 x 130 ISO 4762-p	4			
16*	0302.31	NUT CAP	DADO	2			
17*	0302.30	NUT	DADO M12 UNI5588	2			
18*	1400.05	WASHER	ROSETTA	2			
19*	3604.87	VALVE ASSEMBLY	VALVOLA PREMONTATA	6			
20*	0604.23	VALVE CAGE	GABBIA VAM IMPILATA	3	◆	◆	◆
21*	0009.55	BACK RING	ANELLO ANTIESTR.	6			
22*	0601.66	O-RING	O-RING	3			
23*	1503.44	VALVE SEAT	SEDE VAM	6			
24*	1202.13	VALVE PLATE	PIATTELLO VAM	6			
25*	0900.39	VALVE SPRING	MOLLA VAM	6			
26*	0604.12	VALVE CAGE	GABBIA VAM	6			
27*	1601.84	VALVE SPACER CAP	DISTANZIALE TAPPO VAM	3			
28*	0605.25	O-RING	O-RING	3			
29*	0009.54	BACK RING	ANELLO ANTIESTR.	3			
30*	0203.91	MANIFOLD HOUSING COVER	COPERCHIO TESTATA	3			
31*	1403.06	WASHER	ROSETTA	6			
32*	1801.53	COVER SCREW	VITE COPERCHIO TESTATA	6			
33	1802.05	BEARING HOUSING SCREW	VITE FLANGIA CUSCINETTI	12			
34	1400.01	WASHER	ROSETTA M8 UNI 6592V	12			
35	0500.88	BEARING HOUSING	FLANGIA CHIUSA	1			
36	0301.29	SHIM 0,1mm	DISTANZIALE FLANGIA 0,1mm	1			
	0301.31	SHIM 0,05mm	DISTANZIALE FLANGIA 0,05mm	1			
37	0601.00	O-RING	O-RING	2			
38	0200.14	ROLLER BEARING	CUSCINETTO	2			
39	0006.94	CRANKSHAFT SPTO Ø30	ALBERO SPTO Ø30	1	◆		
	0006.96	CRANKSHAFT SPTO Ø30	ALBERO SPTO Ø30	1		◆	
	0006.97	CRANKSHAFT SPTO Ø30	ALBERO SPTO Ø30	1			◆
40	0206.08	CRANKSHAFT KEY	LINGUETTA	1			
41	1800.16	EYEBOLT	GOLFARE	1			
42	1600.16	OIL DIP STICK	TAPPO SFIATO OLIO	1			
43*	0301.28	MANIFOLD HOUSING SPACER	TIRANTE TESTATA	2			
44*	1407.58	FITTING	RACCORDO	6			
45*	1605.24	RED PIPE	TUBO ROSSO	4			
46	0001.92	PLUNGER OIL SEAL	ANELLO RADIALE	1			
47	0500.89	BEARING HOUSING	FLANGIA APERTA	1			
48*	1802.31	PLUNGER INOX SCREW	VITE INOX PISTONE	3	◆	◆	◆
49*	1400.10	PLUNGER COPPER SPACER	ROSETTA RAME	3			
50*	1200.47	PLUNGER	PISTONE	3			
51*	1400.57	COPPER SPACER	ROSETTA PISTONE	3			
52*	0003.41	PLUNGER ROD	ASTA GUIDA PISTONE	3			
53*	1502.09	CONNECTING ROD PIN	SPINOTTO	3			
54*	0100.12	CONNECTING ROD	BIELLA	3			
55*	1401.03	SCHNORR WASHER	ROSETTA SCHNORR	6			
56*	1801.01	CONNECTING ROD SCREW	VITE BIELLA	6			

MXT HT

PARTS LIST

LISTA PARTI

<i>Item</i> Posizioni	<i>Part Number</i> Codice	<i>Description</i>	Descrizione	<i>Q.ty Pump</i> Q.tà Pompa	MXT1015HT	MXT8515HT	MXT7015HT
57	0605.12	<i>O-RING</i>	O-RING	1			
58	0203.68	<i>CRANKCASE COVER</i>	COPERCHIO POSTERIORE	1			
59	1801.12	<i>COVER SCREW</i>	VITE COPERCHIO	5			
60	0700.05	<i>SIGHT GLASS G 3/4"</i>	SPIA LIVELLO OLIO G3/4	1	◆	◆	◆
61	1601.17	<i>BRASS PLUG G3/8"</i>	TAPPO G3/8"	1			
62	0601.14	<i>O-RING</i>	O-RING	1			