

# PBO Series 1440 - 1540

## Pompa a 4 membrane-pistone semidrauliche.

Four piston semi-hydraulic diaphragm pump

Мембранно-поршневой насос с 4 полугидравлическими узлами.

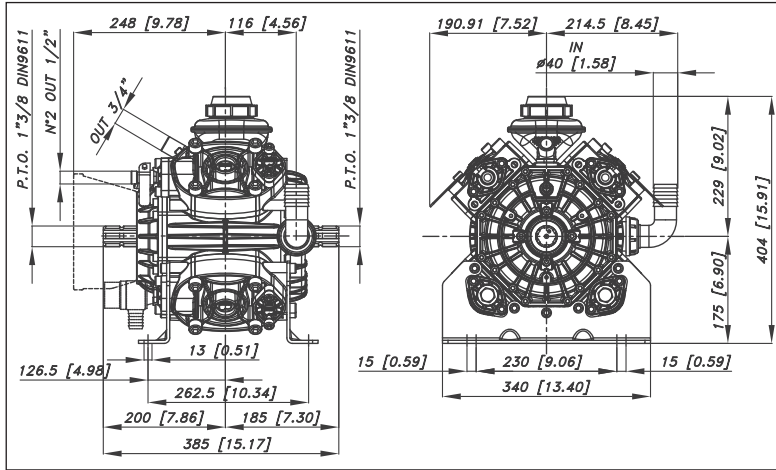

Optional - Optional - По заказу **D** **H** **V**

### Caratteristiche tecniche

Specifications

Технические характеристики

<b>g/min; R.P.M.; об/мин;</b>		<b>g/min.</b>	<b>R.P.M.</b>	550	550
<b>Peso - Weight - Вес</b>		<b>Kg</b>	<b>lb</b>	36	79
<b>Dislivello aspirazione</b> Negative pressure Перепад уровня при всасывании	<b>MAX</b>	<b>mt</b>	<b>ft</b>	1,5	4,9
	<b>Servizio discontinuo</b> Discontinuous service - Прерывистая работа	<b>mt</b>	<b>ft</b>	3	9,8
<b>Ø Aspirazione - Ø Intake - Ø Вход</b>	<b>930</b>	<b>mm</b>	<b>in</b>	40	1" 9/16
<b>Ø Mandata - Ø High pressure - Ø Выход</b>		<b>mm</b>	<b>in</b>	6. 3/4	6. 3/4
<b>Max. Temperatura - MAX Temperature - Макс. Температура</b>		<b>°C</b>	<b>°F</b>	60	140
<b>Tipo olio - Oil type - Тип масла</b>		<b>SAE</b>	<b>W</b>	30	30
<b>Capacità olio - Oil capacity - Объем масла</b>		<b>lt</b>	<b>U.S.G.</b>	1,25	0,33

### ALBERO POMPA - PUMP SHAFT - ВАЛ НАСОСА



● ANT. - FRONT - ПЕР.



● POST - REAR - ЗАД.

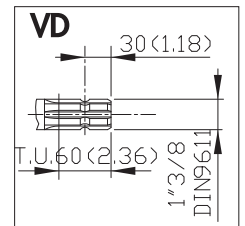
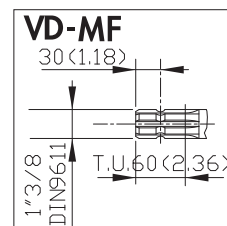

● POST - REAR - ЗАД.



● POST - REAR - ЗАД.

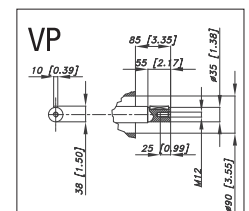
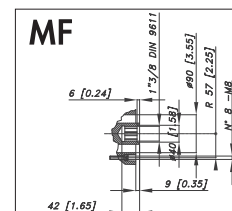

### ACCESSORI - ACCESSORIES - АКССУАРЫ



ACCESSORI D'AZIONAMENTO  
DRIVE ACCESSORIES

Pag. 105

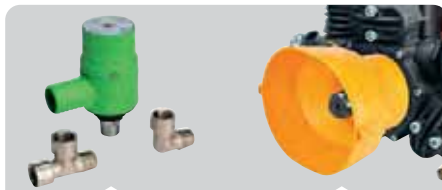

DISPOSITIVI DI SICUREZZA  
SAFETY ACCESSORIES

Pag. 106



Pag. 106



FILTRI  
FILTERS

Pag. 107



GRUPPI DI COMANDO  
CONTROL UNITS

Pag. 92



COMPUTER E PANNELLI  
COMPUTERS AND SPRAYERS CONTROL

Pag. 150

## PBO 1440

41.7015.97.3 - VD  
41.7016.97.3 - MF  
41.7017.97.3 - VP

**TABELLA RENDIMENTI - PERFORMANCE CHART**  
**ТАБЛИЦА ПРОИЗВОДИТЕЛЬНОСТИ**

g/min R.P.M.: об/мин; ▶	400		450		500		550	
	L/min USGPM	KW HP	L/min USGPM	KW HP	L/min USGPM	KW HP	L/min USGPM	KW HP
2	99,6	0,4	112,1	0,4	124,5	0,5	137,0	0,5
29	26,3	0,5	29,6	0,6	32,9	0,7	36,2	0,7
20	97,5	3,8	109,6	4,3	121,8	4,8	134,0	5,3
290	25,7	5,1	29,0	5,8	32,2	6,4	35,4	7,0
40	96,0	7,5	108,0	8,5	120,0	9,4	132,0	10,4
580	25,4	10,1	28,5	11,3	31,7	12,6	34,9	13,9
50	95,3	9,4	107,2	10,5	119,1	11,7	131,0	12,9
725	25,2	12,5	28,3	14,1	31,5	15,6	34,6	17,2



## PBO 1540

41.7112.97.3 - VD  
41.7113.97.3 - MF  
41.7114.97.3 - VP

**TABELLA RENDIMENTI - PERFORMANCE CHART**  
**ТАБЛИЦА ПРОИЗВОДИТЕЛЬНОСТИ**

g/min R.P.M.: об/мин; ▶	400		450		500		550	
	L/min USGPM	KW HP	L/min USGPM	KW HP	L/min USGPM	KW HP	L/min USGPM	KW HP
2	112,0	0,4	126,0	0,5	140,0	0,5	154,0	0,6
29	29,6	0,6	33,3	0,7	37,0	0,7	40,7	0,8
20	109,1	4,3	122,7	4,8	136,4	5,4	150,0	5,9
290	28,8	5,7	32,4	6,4	36,0	7,2	39,6	7,9
40	107,6	8,5	121,1	9,5	134,5	10,6	148,0	11,6
580	28,4	11,3	32,0	12,7	35,5	14,1	39,1	15,5
50	106,9	10,5	120,3	11,8	133,6	13,1	147,0	14,4
725	28,2	14,0	31,8	15,8	35,3	17,5	38,8	19,3

