

	EQUIPAGGIAMENTI TECNICI LAVAGGIO	TESTINE ROTANTI MOD. M21E	(I) (GB)	4 11
			12.9411.00	20/12/05

# M21E

25.4300.00 (I)  
25.4300.24 (AUS)  
25.4300.60 (USA)  
25.4300.62 (J)

MANUALE D'ISTRUZIONE  
GENERAL INTRUCTION BOOK

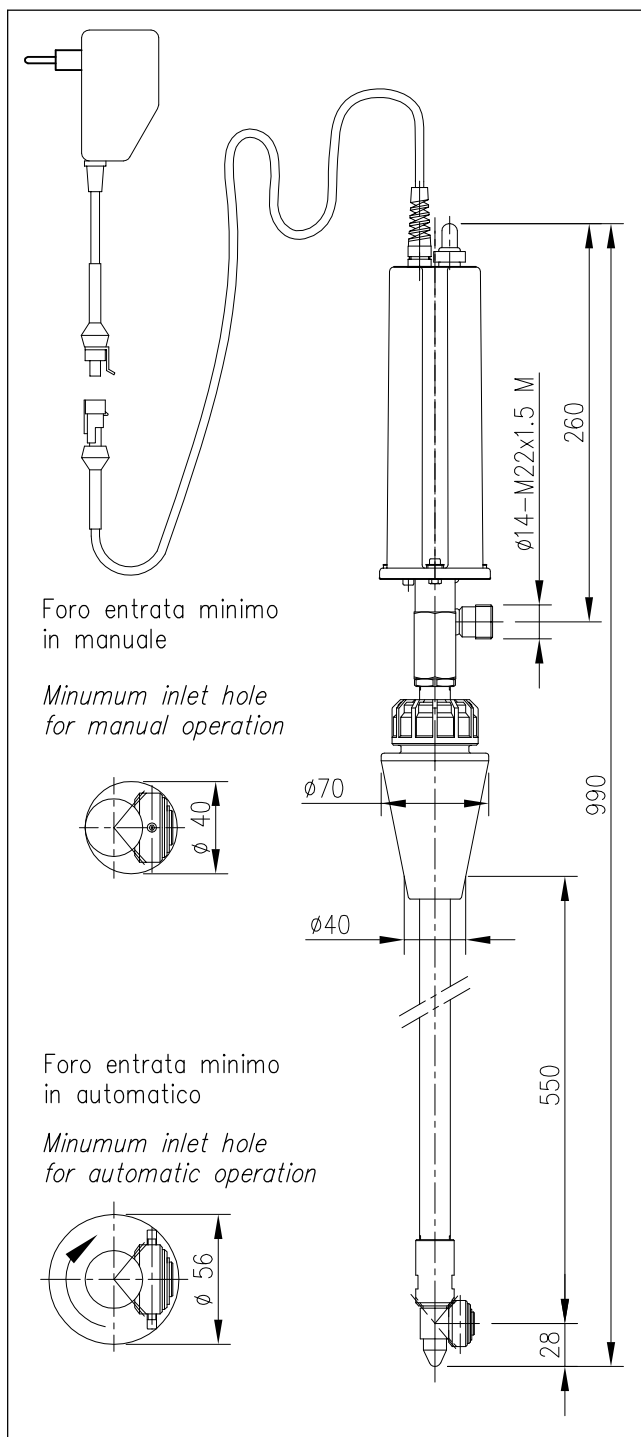
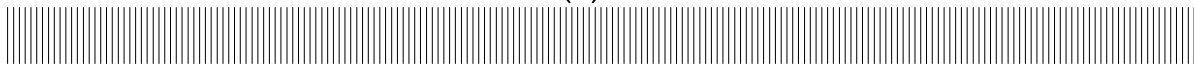

## TESTINA ELETTRICA PULIZIA CISTERNE

- Lavaggio superfici interne di contenitori e serbatoi.
- Portata ridotta, alta pressione, elevata forza di impatto.
- Copertura orbitale completa degli interni.
- Minimo ingombro radiale che ne permette l'introduzione attraverso passaggi ridotti.
- Alimentazione elettrica a bassa tensione.
- Costruzione in acciaio inox.
- Idonea per impiego settore alimentare.

### ATTENZIONE !

- La Testina STANDARD è fornita di guarnizioni (DINAMICHE) in PTFE + O-Ring EPDM.
- Lubrificare esclusivamente con GRASSO SILICONICO codice: 14.6552.00
- Per l'utilizzo di liquidi detergenti, additivi chimici ecc. non compatibili con le guarnizioni standard è indispensabile contattare il nostro UFFICIO TECNICO.
- A richiesta le guarnizioni (DINAMICHE) O-RING sono disponibili anche in diverso materiale, NBR-FFKM(kalrez)-FKM(viton).

## ELECTRIC TANK CLEANING HEAD

- Cleaning of interior surfaces of tanks and drums.
- Reduced flow, high pressure, high cleaning impact.
- Complete orbital coverage of all interior surfaces.
- Small spray turret that fits through reduced tank opening.
- Low tension electric power.
- Stainless steel construction.
- Suitable for utilization in food industry.

### ATTENTION !

- The STANDARD Tank cleaning head is supplied with seals (DYNAMIC) in PTFE + O-Ring EPDM.
- Lubricate ONLY with SILICONE GREASE P/N: 14.6552.00
- For use with Detergent liquid, Chemical additives etc that are not compatible with the standard seals, it is essential to contact our TECHNICAL OFFICE for further information.
- On request, the O-RING seals (DYNAMIC) are available in different materials such as NBR-FFKM(kalrez)-FKM(viton).

**ATTENZIONE: NON UTILIZZARE  
L'APPARECCHIO PRIMA DI AVER LETTO  
QUESTO MANUALE DI ISTRUZIONE**

**CAUTION: DO NOT USE THE  
CLEANING HEAD BEFORE HAVING READ  
THE INSTRUCTION BOOK**

# CARATTERISTICHE TECNICHE TECHNICAL SPECIFICATIONS

M21E



- PRESSIONE NOMINALE <i>RATED PRESSURE</i>	220 bar – 22 MPa (3200 psi)
- PRESSIONE CONSENTITA <i>PERMISSIBLE PRESSURE</i>	250 bar – 25 MPa (3650 psi)
- PORTATA MASSIMA <i>MAX FLOW RATE</i>	21 l/min (5.5 USGp.m.)
- TEMPERATURA MASSIMA ACQUA <i>MAX WORKING TEMPERATURE</i>	90 °C (195°F)
- PESO <i>WEIGHT</i>	3.2 Kg
- FREQUENZA ROTAZIONE ASSE PRINCIPALE <i>MAIN AXIS ROTATING SPEED</i>	14 RPM
- ATTACCO ALIMENTAZIONE ACQUA <i>INLET CONNECTION SIZE</i>	ø14–M22x1.5 M (A)
- ATTACCO UGELLI N°2 <i>NOZZLES CONNECTION N°2</i>	M4
- TEMPO PER UN CICLO COMPLETO DI LAVAGGIO <i>TIME FOR A COMPLETE CLEANING CYCLE</i>	2 min
- MOTORE ELETTRICO: <i>ELECTRIC MOTOR:</i>	8W – 12V.cc
- ALIMENTATORE: <i>POWER SUPPLY:</i>	25.4300.00 – 230V–50Hz/12V.cc–1A 25.4300.24 – 240V–50Hz/12V.cc–1A 25.4300.60 – 110V–60Hz/12V.cc–0.8A 25.4300.62 – 100V–60Hz/12V.cc–1A
-LUNGHEZZA CAVO ALIMENTAZIONE: <i>POWER CABLE LENGTH</i>	10 m
- TENUTE ( N.B. USARE SOLO GRASSO AL SILICONE codice: 14.6552.00) <i>SEALS ( N.B. USE P/N: 14.6552.00 SILICONE GREASE ONLY )</i>	EPDM+PTFE

## CADUTA DI PRESSIONE IN FUNZIONE DELLA PORTATA

### LOSS OF PRESSURE IN RELATION TO FLOW

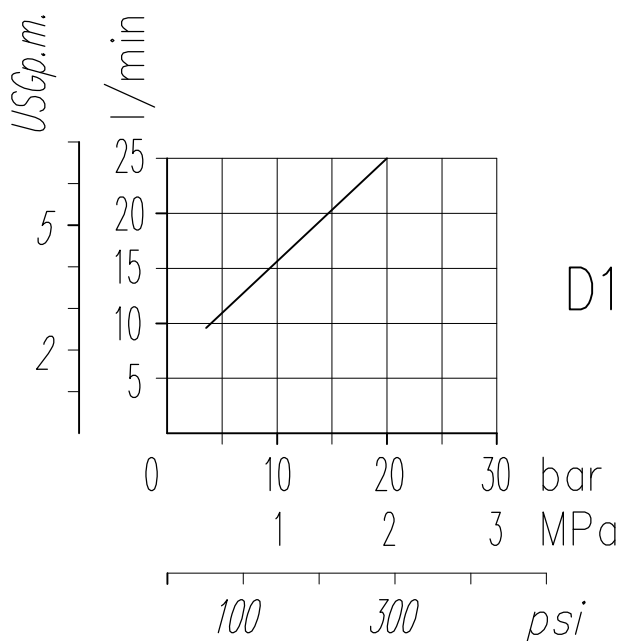

## D2

### UGELLI – NOZZLES

	codice	D(mm)	l/min(100bar)	F.P.
*	80.0350.51	1.00	4.6	02
	25.1191.51	1.05	5	023
*	80.0351.51	1.10	5.6	025
	25.1192.51	1.15	6.1	027
*	80.0352.51	1.20	6.7	03
	25.1193.51	1.25	7.1	032
*	80.0353.51	1.30	7.8	035
	25.1098.51	1.35	8.4	037
*	80.0354.51	1.40	9.1	04
	25.1194.51	1.45	9.7	043
	25.1095.51	1.50	10.3	045
	25.1195.51	1.55	11.2	05
	25.1196.51	1.60	12	053
	25.1197.51	1.62	12.6	055
	25.1186.51	1.66	13.7	06
	25.1198.51	1.72	14.8	065
	25.1199.51	1.8	16	07
	25.1085.51	2.00	18.2	08

\* Ugelli forniti di serie (tipo corto)

\* Standard nozzles supplied (short type) 11–2



SCELTA INDICATIVA FATTORE DI PORTATA N°2 UGELLI  
 INDICATIVE CHOICE OF FLOW FACTOR N°2 NOZZLES

PRESSIONE bar – MPa – PRESSURE PSI

PORTATA POMPA l/min – PUMP FLOW USGp.m.

21 5,5						215 21.5 3150	180 18 2600	155 15.5 2250	130 13 1900	110 11 1600	100 10 1450	85 8.5 1200
20 5,3						195 19.5 2850	160 16 2300	140 14 2050	120 12 1750	105 10.5 1500	90 9 1300	75 7.5 1100
19 5					200 20 2900	175 17.5 2550	145 14.5 2100	125 12.5 1800	105 10.5 1500	95 9.5 1350	85 8.5 1200	70 7 1000
18 4,8				215 21.5 3150	180 18 2600	160 16 2300	130 13 1900	110 11 1600	95 9.5 1350	85 8.5 1200	75 7.5 1100	60 6 870
17 4,5				190 19 2750	160 16 2300	140 14 2050	115 11.5 1700	100 10 1450	85 8.5 1200	75 7.5 1100	65 6.5 950	55 5.5 800
16 4,2		200 20 2900	170 17 2450	140 14 2050	125 12.5 1800	105 10.5 1500	90 9 1300	75 7.5 1100	65 6.5 950	60 6 870	50 5 725	
15 4		175 17.5 2550	150 15 2200	125 12.5 1800	110 11 1600	90 9 1300	75 7.5 1100	65 6.5 950	55 5.5 800	50 5 725		
14 3,7		195 19.5 2850	155 15.5 2250	130 13 1900	105 10.5 1500	95 9.5 1350	80 8 1150	65 6.5 950	55 5.5 800	50 5 725		
13 3,4	195 19.5 2850	165 16.5 2400	130 13 1900	110 11 1600	90 9 1300	80 8 1150	65 6.5 950	55 5.5 800	50 5 725			
12 3,2	170 17 2450	140 14 2050	110 11 1600	95 9.5 1350	80 8 1150	70 7 1000	55 5.5 800	50 5 725				
11 2,9	140 14 2050	120 12 1750	95 9.5 1350	80 8 1150	65 6.5 950	60 6 870						

FATTORE PORTATA N°1 UGELLO <i>FLOW FACTOR N°1 NOZZLE</i>	*		*		*		*		*			
	02	023	025	027	03	032	035	037	04	043	045	05
N° UGELLI DA MONTARE <i>N° OF NOZZLES TO BE FITTED</i>	2	2	2	2	2	2	2	2	2	2	2	2

\* UGELLI DISPONIBILI TIPO CORTO  
 \* NOZZLES AVAILABLE SHORT TYPE

N.B. E' OBBLIGATORIO MONTARE N°2 UGELLI AVENTI LO STESSO FATTORE DI PORTATA  
 N.B. IT IS MANDATORY TO FIT 2 NOZZLES HAVING THE SAME FLOW FACTOR



**P.A. – S.p.A. – EQUIPAGGIAMENTI TECNICI DEL LAVAGGIO**

VIA MILANO, 13 – CASELLA POSTALE 115 – 42048 RUBIERA (REGGIO EMILIA) – ITALY  
Tel. +39 0522 623611 – Fax. +39 0522 629600 – R.E.A. RE 156319 – R.I. RE11535 – Mecc. RE 013446  
C.F. e P. IVA 01035950359 – Cap. Soc. i.v. € 750.000,00 – Codice Identificativo C.E.E. IT 01035950359  
ART. 2497 – BIS C.C. DIREZIONE E COORDINAMENTO BENETTI srl R.I. TRIB. DI RE 01480690351  
Web: <http://www.pa-etl.it> – E-mail: [info@pa-etl.it](mailto:info@pa-etl.it)



## EU DECLARATION OF CONFORMITY 2014/30/EU

**We under signed declare under our responsibility that the product:**

*Noi firmatari della presente dichiariamo sotto la nostra responsabilità che il prodotto:*

**CLEANING HEAD – M21E – M25E – M28E**  
*ACCESSORIO PER IL LAVAGGIO A TESTINA ROTANTE – M21E – M25E – M28E*

**to which this declaration relates is in conformity with the following standards or other normative document(s):**

*al quale questa dichiarazione si riferisce, è conforme alle seguenti norme:*

- **CEI EN 55014-1:2008 + A1:2010 + A2:2012 – Requirements for household appliances, electric tools and similar apparatus - Part 1: Emission**
- *Prescrizione per gli elettrodomestici, gli utensili elettrici e gli apparecchi similari – Parte 1: Emissione*
- **CEI EN 55014-2:2015 – Requirements for household appliances, electric tools and similar apparatus - Part 2: Immunity - Product family standard**
- *Prescrizione per gli elettrodomestici, gli utensili elettrici e gli apparecchi similari – Parte 2: Immunità – Norma di famiglia per prodotti*
- **CEI EN 60335-1:2013 + A11:2015 – Household and similar electrical appliances - Safety - Part 1: General requirements**
- *Sicurezza degli apparecchi d'uso domestico e similare – Sicurezza – Parte 1: Norme generali*

**following the provisions of the Directive: 2014/30/EU.**

*in base a quanto previsto dalla Direttiva: 2014/30/UE.*

### Restrictions

**When installed with other products or as part of an assembly, the EMC characteristics might change. In this case the manufacturer of the final product has to check the EMC characteristics to ensure that they are still in compliance with EMC Directive.**

### Limitazioni

*Quando installato in altri prodotti o come parte di un insieme, le caratteristiche EMC possono essere alterate. Pertanto in tal caso il costruttore del prodotto finito deve verificare nuovamente le caratteristiche EMC per assicurare che siano ancora in conformità con la Direttiva EMC.*

**We also declare:**

Si dichiara inoltre:

***that the pressure apparatus has been submitted with successful outcome to hydraulic pressure test;***

*che l'attrezzatura a pressione è stata sottoposta con esito favorevole a prova di pressione idraulica.*

Rubiera, lì 24/05/2017.

P.A. SpA  
**Il PRESIDENTE**  
Ing. Arnaldo Benetti

25.4300.00 M21E test.mot.el.220Vca/50Hz  
25.4300.24 M21E test.mot.el.240Vca/50Hz AUS

25.4300.60 M21E test.mot.el.Usa + Australia  
25.4300.62 M21E test.mot.el.100Vca/60Hz JAP

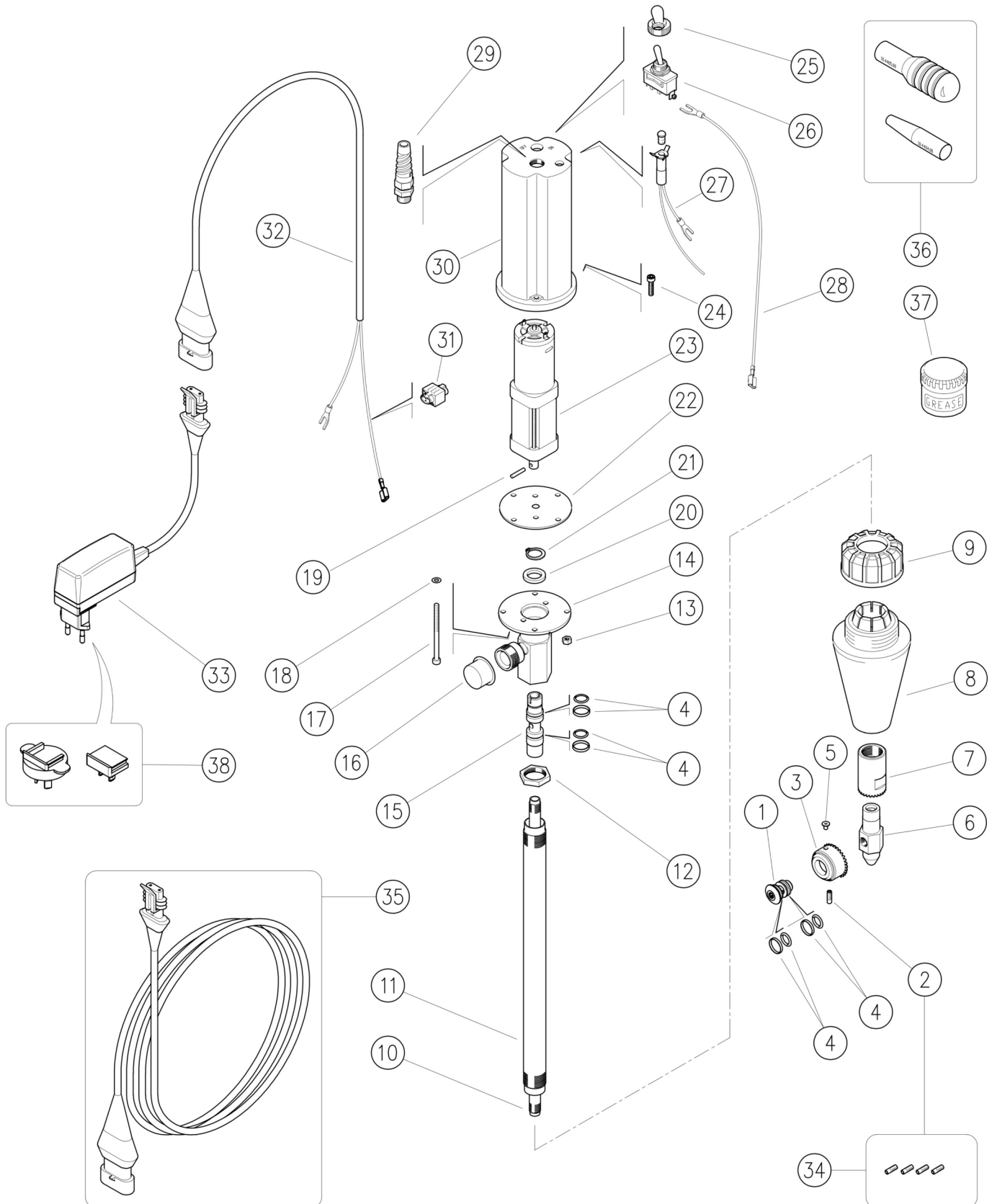

Pos.	Codice	Descrizione	Q.tà	K1	K2	K3	K4	Pos.	Codice	Descrizione	Q.tà	K1	K2	K3	K4
1	80.0313.51R	Perno M10x1 inox	1				1	18	14.3519.00R	Rosetta 4x8x0,5 mm ott.	2				10
2	15.3704.00R	Tappo M4 plast.	2				4	19	15.1030.00R	Spina elast. 3x16 mm inox	1				10
2	80.0350.51R	Ugello 02 - 1,0mm - M4 inox verde ch.	2	•			10	20	80.0302.31R	An. distanziale 13x21x3,8mm	1	•			10
2	80.0351.51R	Ugello 025 - 1,1mm - M4 inox rosa	2	•			10	21	10.1000.13R	An. elast. E 13 inox	1	•			10
2	80.0352.51R	Ugello 03 - 1,2mm - M4 inox bianco	2	•			10	22	80.0317.88R	Guarniz. per motore, NBR	1				10
2	80.0353.51R	Ugello 035 - 1,3mm - M4 inox marrone	2	•			10	23	13.0827.00R	Motoriduttore 12V 10Rpm	1				1
2	80.0354.51R	Ugello 04 - 1,4mm - M4 inox giallo	2	•			10	24	16.1852.10R	Vite DIN912 M4x14 mm inox	4				10
3	80.0312.51R	Pignone portaug. z.29 M4 FF inox	1				1	26	12.5016.20R	Interr.unipol. on/off +protezione	1				3
4	10.2032.00R	Guarn. pistone 10x15x2 mm +OR	4	•			4	27	12.5019.31R	Lampada spia	1				5
5	15.3704.00R	Tappo M4 plast.	2				4	28	12.5019.25R	Cavo 1x0,75 L.250 mm	1				5
6	80.0314.51R	Puntale M10x1 inox	1				1	29	13.5997.00R	Pressacavo 1/4 +protezione	1				5
7	80.0311.51R	Pignone fisso z.24 inox	1				1	30	80.0301.84R	Carter motore PA nero	1				1
8	80.0315.84R	Tappo conico TPEs nero	1				1	31	12.5019.47R	Rubacorrente	1				5
9	80.0316.84R	Ghiera PP nera	1				10	32	12.5019.10R	Cavo 2x1,5 mm 10m+connessione F	1				5
10	80.0310.56R	Tubo M10x1 MM 672mm inox	1				1	33	12.5071.00R	Trasf. 230Vca/12Vcc EU (1)	1				1
11	80.0309.56R	Tubo M20x1 MM 655mm inox	1				1	33	12.5071.24	Trasf. 240Vca/12Vcc AUS (2)	1				1
12	80.0308.51R	Ghiera M20x1 inox	1				1	33	12.5071.60	Trasf. 115Vca-60Hz/12Vcc USA (3)	1				1
13	11.4513.10R	Dado es. M4 inox	4				10	33	12.5071.62R	Trasf. 100Vca-60Hz/12Vcc JAP (4)	1				1
14	80.0304.21R	Collettore inox	1				1	34	25.4320.24R	Kit Ugelli M4 - M21E 2x5pz.	1				1
15	80.0303.51R	Albero di trasmissione inox	1				1	35	25.4353.20R	ProL. -M21E 20m 12Vcc MF **	1				1
16	15.3700.00R	Tappo 20,5 mm pvc	1				10	36	25.4321.24	Kit Attrezzi Montag.Guarn.M21E 2pz. **	1				1
17	16.1860.00R	Vite DIN912 M4x60 mm inox	2				10	37	14.6552.00R	Grass.silicone-teflon-30g.>tutti imp. **	1				2

\*\* Su richiesta

Kit	Codice	Descrizione	Q.tà
K1	25.4320.24R	Kit Ugelli M4 - M21E 2x5pz.	1
K2	25.4308.24	M21E-kit ricam. pz.3(6) x 1	1

(1) 25.4300.00 (2) 25.4300.24 (3) 25.4300.60 (4) 25.4300.62

25.4300.00 M21E Tank cl.,el.-driv., 220V AC/50Hz  
25.4300.24 M21E Tank cl.,el.-driv.,240V AC/50Hz AUS

25.4300.60 M21E Tank cl.,el.-driv.,USA+Austral  
25.4300.62 M21E Tank cl.,el.-driv.,100V AC/60Hz JAP

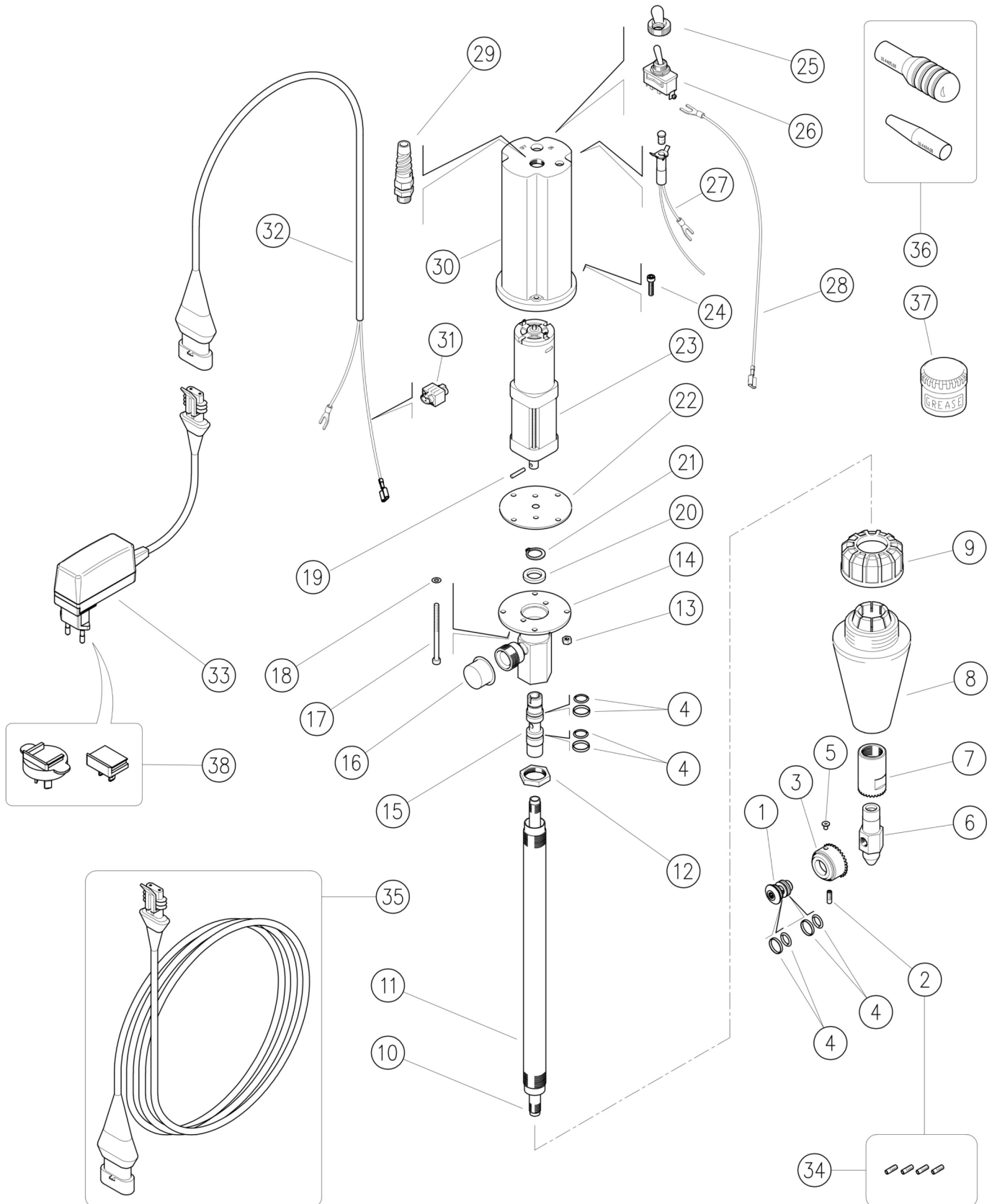

Pos.	P/N	Description	Q.ty	K1	K2	K3	K4	
1	80.0313.51R	Pin, M10x1 Sst.	1					1
2	15.3704.00R	Plug, M4 plast.	2					4
2	80.0350.51R	Nozzle, 025 - 1,0mm - M4 Sst. light green	2	•				10
2	80.0351.51R	Nozzle, 025 - 1,1mm - M4 Sst. pink	2	•				10
2	80.0352.51R	Nozzle, 03 - 1,2mm - M4 Sst. white	2	•				10
2	80.0353.51R	Nozzle, 035 - 1,3mm - M4 Sst. brown	2	•				10
2	80.0354.51R	Nozzle, 04 - 1,4mm - M4 Sst. yellow	2	•				10
3	80.0312.51R	Nzl hold. pinion, z.29 M4 FF Sst.	1					1
4	10.2032.00R	Piston seal, 10x15x2 mm +O-ring	4	•				4
5	15.3704.00R	Plug, M4 plast.	2					4
6	80.0314.51R	Buffer, M10x1 Sst.	1					1
7	80.0311.51R	Fixed pinion, z.24 Sst.	1					1
8	80.0315.84R	Tapered plug, TPEs black	1					1
9	80.0316.84R	Ring nut, PP black	1					10
10	80.0310.56R	Tube, M10x1 MM 672mm Sst.	1					1
11	80.0309.56R	Tube, M20x1 MM 655mm Sst.	1					1
12	80.0308.51R	Ring nut, M20x1 Sst.	1					1
13	11.4513.10R	Hex. nut, M4, Sst.	4					10
14	80.0304.21R	Manifold, Sst.	1					1
15	80.0303.51R	Propeller shaft, Sst.	1					1
16	15.3700.00R	Plug, 20,5 mm pvc	1					10
17	16.1860.00R	Screw, DIN912 M4x60 mm Sst.	2					10

Pos.	P/N	Description	Q.ty	K1	K2	K3	K4	
18	14.3519.00R	Washer, 4x8x0,5 mm brass	2					10
19	15.1030.00R	Roll pin, 3x16 mm Sst.	1					10
20	80.0302.31R	Spacer ring, 13x21x3,8mm	1	•				10
21	10.1000.13R	Snap ring, E 13 Sst.	1	•				10
22	80.0317.88R	Motor seal, NBR	1					10
23	13.0827.00R	Gearmotor, 12V 10Rpm	1					1
24	16.1852.10R	Screw, DIN912 M4x14 mm Sst.	4					10
26	12.5016.20R	On/off unipol. switch+protec.	1					3
27	12.5019.31R	Pilot lamp	1					5
28	12.5019.25R	Cable, 1x0,75 L.250 mm	1					5
29	13.5997.00R	Cable gland 1/4 +protection	1					5
30	80.0301.84R	Motor casing, PA black	1					1
31	12.5019.47R	Wire tap-in	1					5
32	12.5019.10R	Cable, 2x1,5 mm 10m+F connection	1					5
33	12.5071.00R	Transf. 230VAC/12VDC EU (1)	1					1
33	12.5071.24	Transf. 240VAC/12VDC AUS (2)	1					1
33	12.5071.60	Transf. 115VAC-60Hz/12VDC USA (3)	1					1
33	12.5071.62R	Transf. 100VAC-60Hz/12VDC JAP (4)	1					1
34	25.4320.24R	Nozzle kit M4 - M21E 2x5pcs.	1					1
35	25.4353.20R	Exten.-M21E 20m 12V DC MF **	1					1
36	25.4321.24	Seal Setup Tool Kit - M21E 2pcs. **	1					1
37	14.6552.00R	Teflon silicon grease x30g.>All **	1					2

\*\* On request

Kit	P/N	Description	
K1	25.4320.24R	Nozzle kit M4 - M21E 2x5pcs.	1
K2	25.4308.24	Spares kit -M21E 3(6)x1 pcs	1

(1) 25.4300.00 (2) 25.4300.24 (3) 25.4300.60 (4) 25.4300.62